

FORENSIC SCIENCE STUDY MATERIAL

UNIT IV

(FORENSIC BALLISTICS)

BY

Mr. ABHISHEK KUMAR

Assistant professor

College of law and legal studies

Teerthankar Mahaveer University

PART A – FORENSIC BALLISTICS

INTRODUCTION

Have you ever wondered how the culprit is arrested by the police in cases that involve attacks by firearms? You must have come across many cases in which an individual shoots someone by firing bullets and then runs away from the crime scene. Such criminals are held accountable for their crimes after an investigation of the case by a forensic ballistics examiner. These are the examiners who handle the task of weapon analysis through microscopic methods and are known as ballistics experts. Here in this blog, we have given the complete details on forensic ballistics, syllabus, career opportunities, etc.

What Is Forensic Ballistics?

The [branch of forensic science](#) that deals with the examination of firearms, ammunition, and projectile motions of the missiles in crime mystery solving is known as Forensic Ballistics. Such experts reconstruct the series of events that happened during the gunshot injury and thus conclude the case by presenting their point in front of the legal system.

The ballistics experts are able to give precise readings about the weapon that has been used for committing the crime.

Application of Forensic Ballistics:

This branch of [forensic science](#) deals with criminal cases like homicide, suicide, murder, local gang wars, firearms seizure, black marketing of firearms, and firearm-caused injuries. Since the evidence associated with ballistics is fragile and the chances of their tampering are really high. Hence, it requires professionals in this field to be attentive and critical thinkers during the collection and examination of such evidence.

Forensic Ballistics also known as forensic firearm examination is used in the reconstruction of a crime scene that involves the use of a firearm. Along with this, it also enables the crime investigators to trace the weapon that is used for committing such a crime and thus give a lead to the identification of the suspect.

The primary role of a ballistic examiner is to deal with the distance of fire, firing angle, and series of weapons used thus finally revealing the identity of the criminal also. These professionals match the recovered bullets, and discharged casings of the firearms. These

people primarily rely on recovered bullet, gunpowder residues, casings, and firearms collected as evidence from the crime scene.

Types of Forensic Ballistics:

Forensic Ballistics is a wide open field that opens several gates of firearms investigation to the examiners. But when it comes to investigation, ballistics is divided into four major categories along with several minor categories. However, we will be only discussing the major ones here.

1. Internal Ballistics:

This branch of forensics deals with all and every kind of material present inside a firearm. Along with this, it also deals with the kind of process that takes place when firing takes place till the bullet enters the projectile motion before leaving the gun barrel. The primary role associated with this kind of ballistics is to study the size and shape of the propellant, its ignition process, factors affecting internal functioning, ignition time, etc.

2. External Ballistics:

This branch deals with factors that play a major role while the bullet enters the projectile

motion till the moment it hits the target. The factors that are studied for the investigation of ballistics are air resistance, yaw, trajectory computation, velocity, vacuum trajectory, etc.

3. Transitional Ballistics:

It is the intermediate process between the internal and external ballistics process when the bullet leaves the barrel and before it hits the target.

3. Terminal Ballistics:

It deals with the impact a projectile object creates when it hits the target and studies factors like bullet shape, velocity of striking, angle of strike, ricochet, and stopping power. Apart from these factors, the branch also deals with wounds caused by firearms and the nature of impact.

What is Forensic Ballistics?

Ballistics = the study of projectiles (bullets) and firearms.



Forensic ballistics is the scientific analysis or interpretation of all ballistic related evidence with the purpose of Interpreting and establishing the facts in a shooting related crime



A LITTLE HISTORY LESSON

- The invention of gunpowder led to the development of firearms.
- Gun powder first appeared in use in China over a thousand years ago, but was used primarily in fire crackers and only sparingly in weapons for military use (canons and such).
- The knowledge of gunpowder manufacture spread to Europe in the 14th century did not at first lead to military usage.
- Once they realized how much damage a projectile can do to a knight's armor or a fortification, the use of firearms proliferated rapidly.

HOW DOES GUN POWDER (BLACK POWDER) WORK?



- Gunpowder, made of a mixture of
 - sulfur,
 - charcoal, and
 - saltpeter (potassium nitrate)
- Its explosive force is due to the fact that 1 mole of solid powder will, when ignited, produce 6 moles of gas.
- This rapid expansion in the enclosed space of a metal tube could be used to drive a projectile at high speed in a specified direction.
- Modern gun powder is a more refined version of the primitive gun powder
- In modern gun powder, the chemical composition has been altered to provide the greatest expansion with the smallest quantity of gun powder and the least amount of residue.

BALLISTIC EVIDENCE HELPS POLICE ANSWER THE FOLLOWING QUESTIONS PERTAINING TO A CRIME SCENE.

- 1. What type of fire arm was used?
- 2. What was the caliber of the bullet?
- 3. How many bullets were fired?
- 4. Where was the shooter standing?
- 5. What was the angle of impact?
- 6. Has this fire arm been used in a previous crime?
- Caliper = a measure of the inside diameter of a firearm barrel.

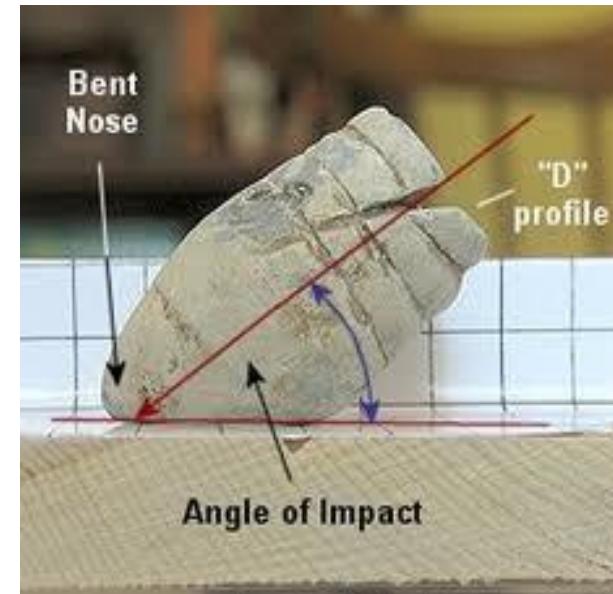



Related evidence includes

- (a) Fire arms or guns**
- (b) bullets**
- (c) cartridge cases**



- **Firearm= A weapon capable of firing a projectile using a confined explosive as a propellant.**
- **Bullet= the projectile that is released when the fire arm is discharged.**
- **Bullet primer= a device for igniting the powder charge**
- **Cartridge= a case that holds a bullet, primer powder and gun powder.**

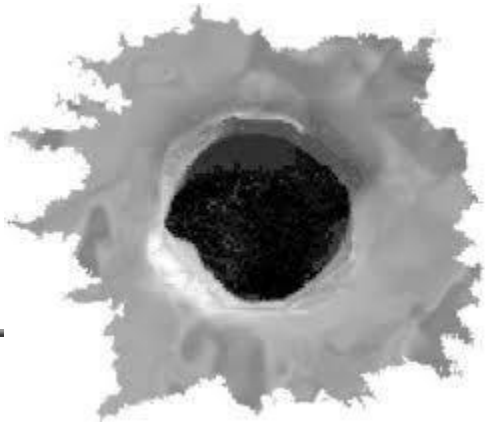

The most common types of crime scene evidence Includes:

- (a) Bullet holes**
- (b) Bullet damage on various mediums**
- (c) Bullet trajectories**
- (d) Gunshot wounds**
- (e) Trajectory=the path of flight of the trajectory**
- (f) Bullet casings**

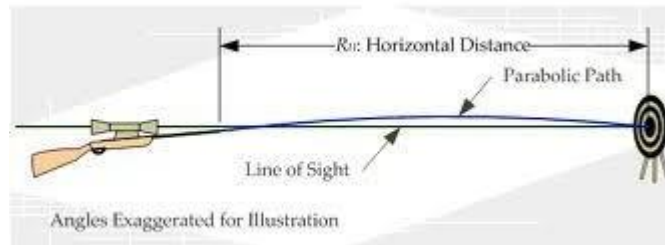

THE ANATOMY OF A CARTRIDGE

The typical cartridge is composed of

- The **bullet**: - It's the actual projectile that comes out the loud end of the gun.
- The **casing** or **shell**: - It encloses everything.
- The **powder**:- This is the stuff that combusts and propels the bullet out of the loud end of the gun.
- The **rim**: - This is what the extract or grabs to eject spent casings.
- The **primer**: - This is what the firing pin hits, which then ignites the gunpowder, which then propels the bullet out of the loud end of the gun.

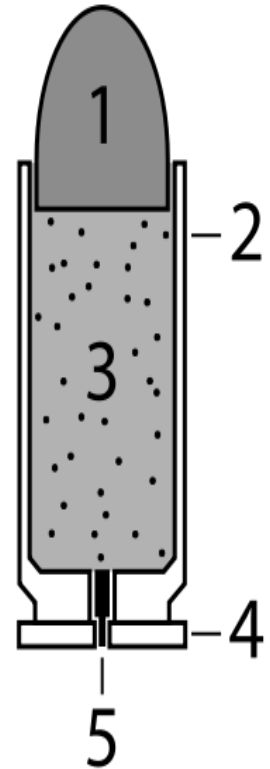

Caliber of the Cartridge

- In guns including firearms, **caliber** or **caliber** is the approximate internal diameter of the barrel in relation to the diameter of the projectile used in it.
- Bullets are named by caliber and length.
- Some common calibers include: .22,.25,.357,.38,.44,.45.
- They are usually measured in hundreds of an inch.
- Ex.:A.45-caliber cartridge measures 45/100 of an inch in diameter.

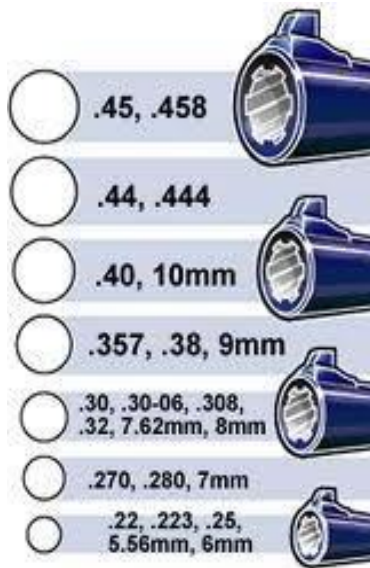

What are the basic types of bullets?

Ogive= the curve of the bullet's forward section



TIP SHAPES

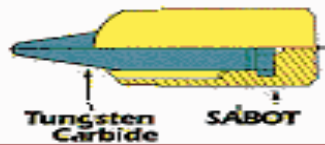

Tungsten Carbide SABOT

Full Metal Jacket



Soft Point



Hollow Point



OGIVE SHAPES

Spitzer



Round Nose



Flat Nose



Semi-wadcutter



Wadcutter



HEEL SHAPES

Flat Base



Boat Tail



How Does A Firearm Work?

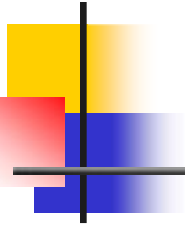

■ This is a revolver

■ 1. Barrel:- The barrel is the part the bullet moves through after it is fired. The muzzle is the open end of the barrel that the bullet exits the gun through

■ 2. Action:- The action is the part that has the mechanism that fires the bullet.

■ 3. Grip or Stock: - Is the handle. It's a grip on a handgun and a stock on a long gun.

■ 4. Trigger Guard: - The piece around the trigger that protects it from getting bumped.

■ 5. Trigger: - The part your finger pulls to make the gun fire.

■ 6. Sights: - Sights come in various styles. Most firearms have a front sight at the muzzle end of the barrel, and a rear sight at the back end of the barrel.

Forensic officer labeling crime scene evidence

1. Make a list of all the evidence that you see in this crime scene the forensic specialist who will analyze this evidence in order to solve this crime.

2. Now assume the role of one forensic specialist and report your analysis. **Example: Ballistics Expert** Weapon is fully functional and in good operating condition.

The barrel of the weapon is clean with faint traces of carbon observed, consistent with a single shot being fired following the last cleaning.

Bullet recovered from east wall of crime scene (Evidence # 001023-03) is a ballistic match to this weapon.

Bullet recovered during autopsy (Evidence#001023-013) is not a ballistic match to this weapon.

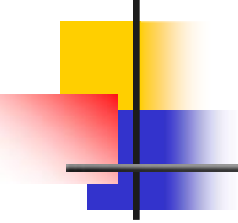

COMPARISON OF RIFLING MARKS

- 
-
- No two rifled barrels are alike.
 - Even made one after another, by the same manufacturer, the rifling process can never be identical.
 - As the bullet is expelled through a barrel, the rifling causes it to spin.
 - The rifling also leaves impressions on the surface of the bullet.
 - These indentations on the bullet can help identify the firearm used.
 - Rifling is the process or operation of cutting spiral grooves in a rifle barrel.

Rifle, Handgun, and Shotgun Bores

Rifle or Handgun Barrel

The bore of a rifle or handgun is **grooved**, which puts a spiral spin on the bullet for greater accuracy.

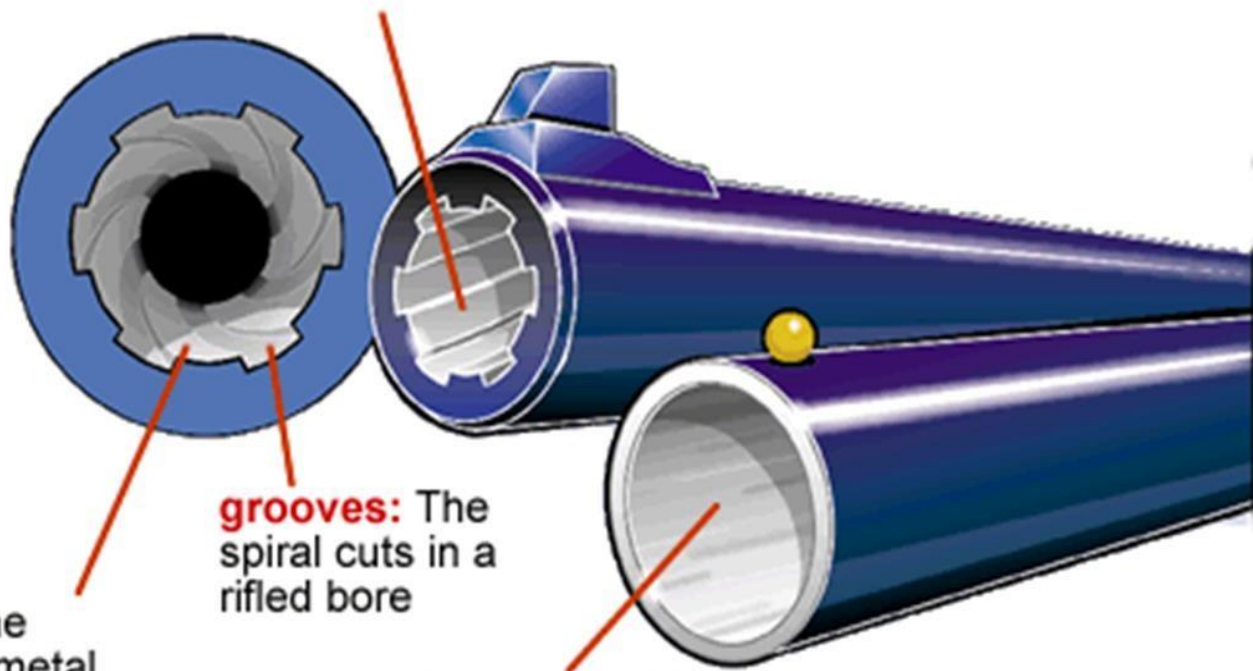

lands: The ridges of metal between the grooves in a rifled bore

grooves: The spiral cuts in a rifled bore

Shotgun Barrel

The bore of the shotgun barrel is **smooth** because rifling would spread the shot pattern too soon.

Comparison Microscope

- **Bullets** collected for comparison to a specific firearm are examined first to see if they are of a **caliber** that could have been fired from the submitted firearm. They are then examined to determine if the pattern of **rifling impressions** found on the bullet match the pattern of **rifling** contained in the barrel of the questioned firearm. If these class characteristics agree the next step is to try to make a positive match between the individual characteristics that may have transferred to the bullet from the barrel.
- The comparison microscope consists of two microscopes mounted side by side and connected by an optical bridge. There are two stages on the lower part of the microscope that the bullets to be compared are mounted on.
- *Magnifications typically used in firearms identification are 5X, 10X, 20X, 30X, and 40X.

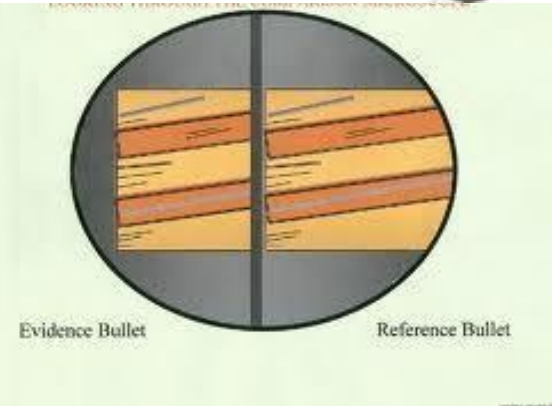

The bullet on the left was fired from an automatic pistol, and the rifling grooves are the same distance apart from top to bottom. The bullet on the right was fired from a revolver, and the grooves are wider at the top than at the bottom, due to slippage.



Exhibit 2 - Matched striations on two bullets

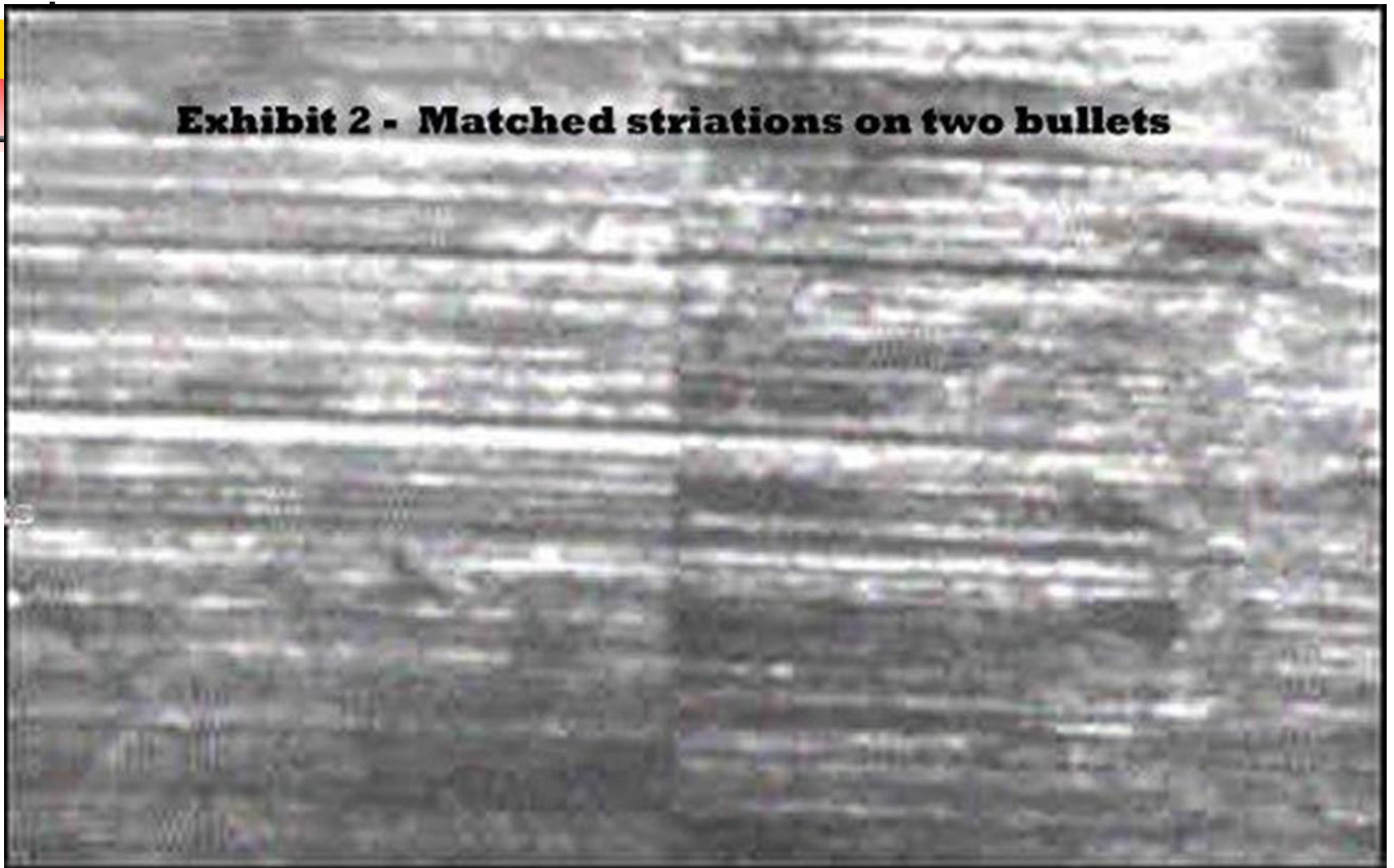

COMPARISON OF FIRING PIN INDENTATIONS

- Examination of some ballistic characteristics can be done with the naked eye. Cartridge on the left was fired from a "Glock" automatic pistol, as for the one on the right, it could have been fired from many different guns, and closer examination is required.



Two cartridges with the same firing pin imprint—positive I.D.

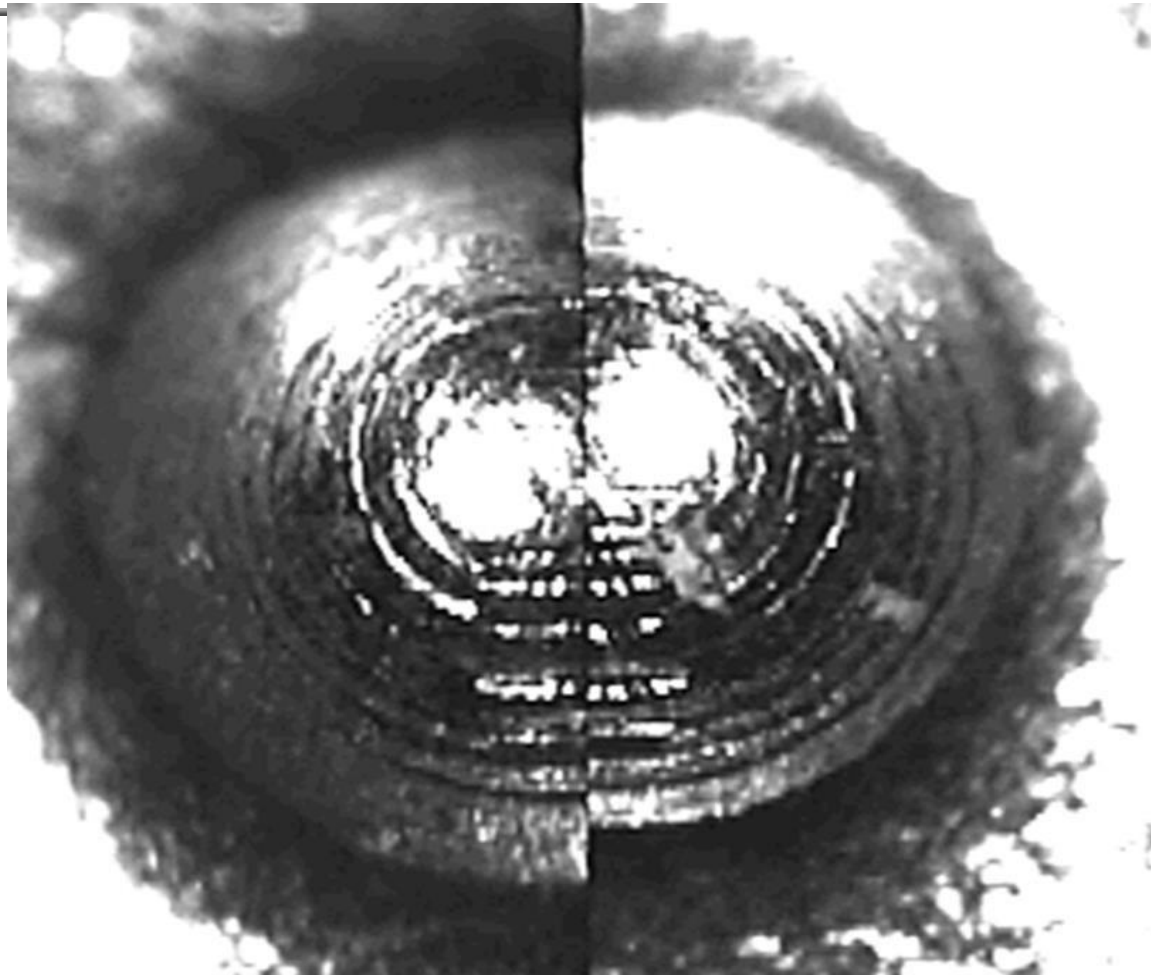

BULLET COMPARISON

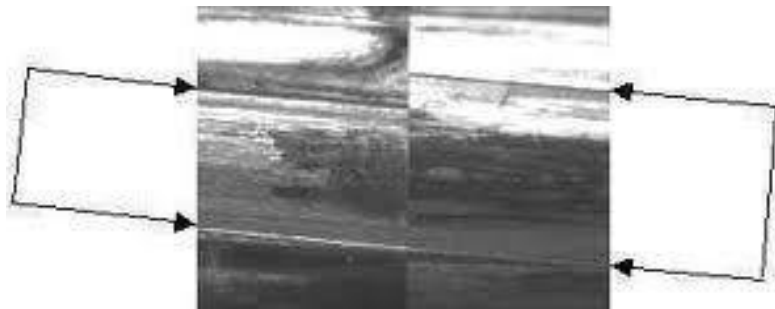
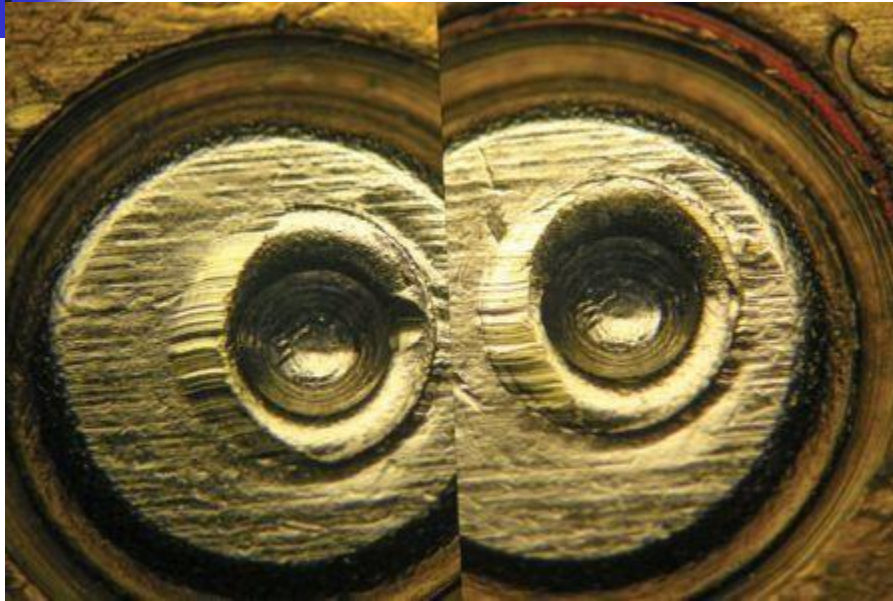
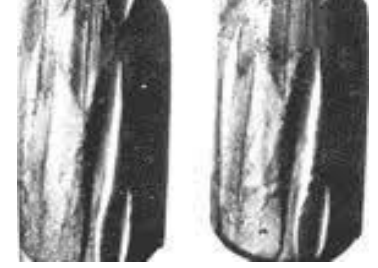



➤ **Forensics Ballistics is divided into 3 sub- categories**

(a) internal

(b) external

(c) terminal ballistics



INTERNAL BALLISTICS

Internal ballistic is the study of the processes occurring inside a firearm when a shot is fired. The most common types of internal ballistics are:

- (a) examining mechanism to determine the causes of accidental discharge**
- (b) examining home-made devices to determine if they are capable of discharging ammunition effectively**
- (c) microscopic examination and comparison of fired bullets and cartridge cases to determine whether a particular firearm was used**

note:- A comparison microscope is a device used to analyze side-by-side specimens

EXTERNAL BALLISTICS

The study of the projectile's flight from the moment it leaves the muzzle of the barrel until it strikes the target.

The 2 most common types of external ballistics examinations are:

- (a) the calculation and reconstruction of bullet trajectories
- (b) establishing the maximum range of a given bullet

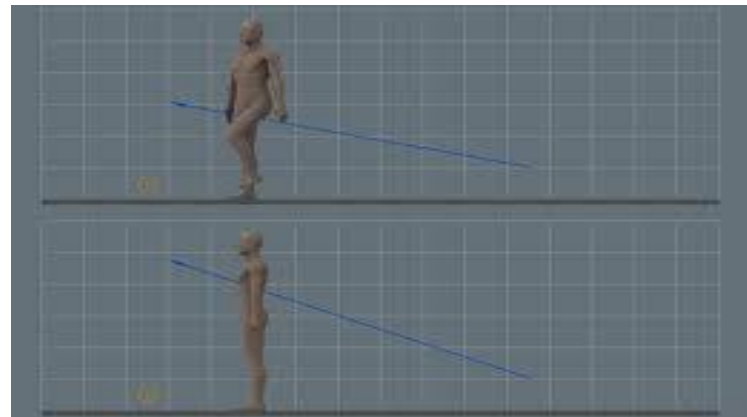
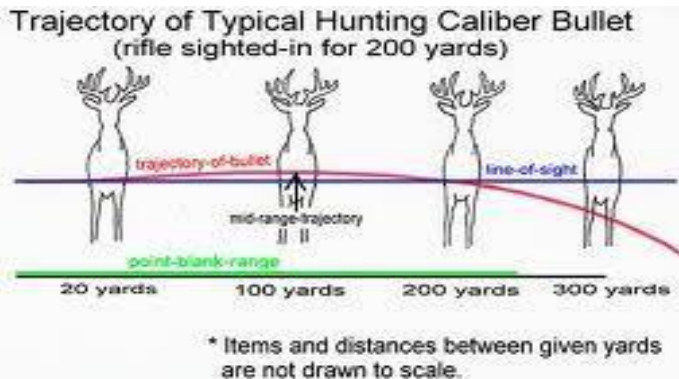



TERMINAL BALLISTICS

Terminal ballistic is the study of the projectile's effect on the target or the counter- effect of the target on the projectile. The 'target' can be any solid or liquid object, but when the target is a human or animal it is common to use the term "wound ballistics".

Common types of terminal ballistics examinations are:

- (a)** Determination of the distance between firing point and target.
- (b)** Establishing whether or not a particular wound was caused by a fired bullet.
- (c)** Determining the caliber and type of projectile that caused bullet damage or gunshot wound.
- (d)** Examination of bullet exit/entrance by examining the holes in targets, or the wounds in biological tissue.
- (e)** Examination of ricochet possibilities and fired projectiles.



GUNSHOT INJURIES

➤ **The seriousness of gunshot wounds depends on 5 factors**

- a. kinetic energy of the bullet
- b. distance to the target
- c. type of tissue
- d. tumbling (flipping around or going straight through)
- e. Bullet design ex. Hollow point, vs. round nose etc.

GUNSHOT WOUNDS (GSW)

- Two types of gunshot wounds:
- Penetrating—the bullet enters, but does not leave the body. This means there is only an entrance wound, and the bullet is somewhere in the body.
- Perforating—The bullet enters and exits the body. This means that there is entrance and exit wound, and the bullet has left the body.

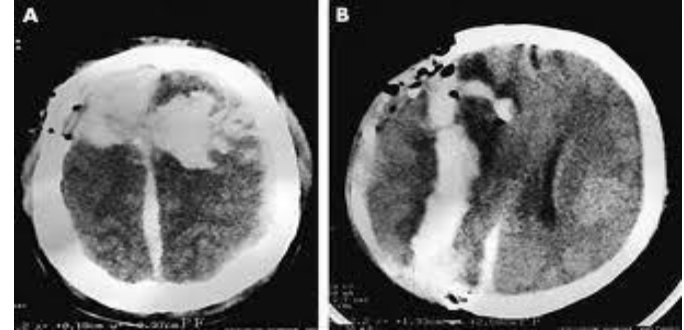

Penetrating gunshot wounds

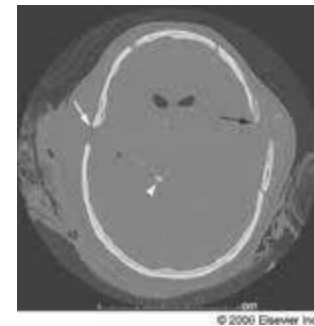

Perforating bullet

WHAT HAPPENS WHEN A BULLET ENTERS THE BODY?

- The bullet hits the skin first, yet it does not penetrate immediately. The bullet pushes on the skin until the skin breaks.
- This can result in the skin being pushed back into the body a considerable distance (very similar to hitting someone with a blunt object).
- Finally the skin breaks and the bullet can enter the body.
- Once the bullet is in the body it creates one or two cavities (hollow spaces). The cavity is created because the tissue is pushed out of the way of the bullet.
- Low power bullets only create a small permanent cavity
- High power bullets create a very large temporary cavity (like a splash in water) and a permanent cavity. It is this temporary cavity that can cause massive wounds.



THE K.E OF THE BULLET IS KEY TO THE AMOUNT OF DAMAGE IT CAN CAUSE

$$KE = 1/2 MV^2$$

Full Metal Jacket (High Speed)

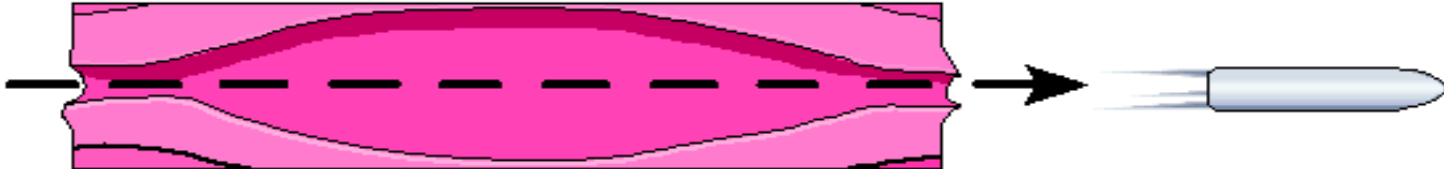

Hunting Rifle (High Speed)



HandGun (Low Speed)



➤ In the diagram below, the difference between temporary and permanent cavitation is shown in terms of color, with the paler color indicating the temporary cavitation.

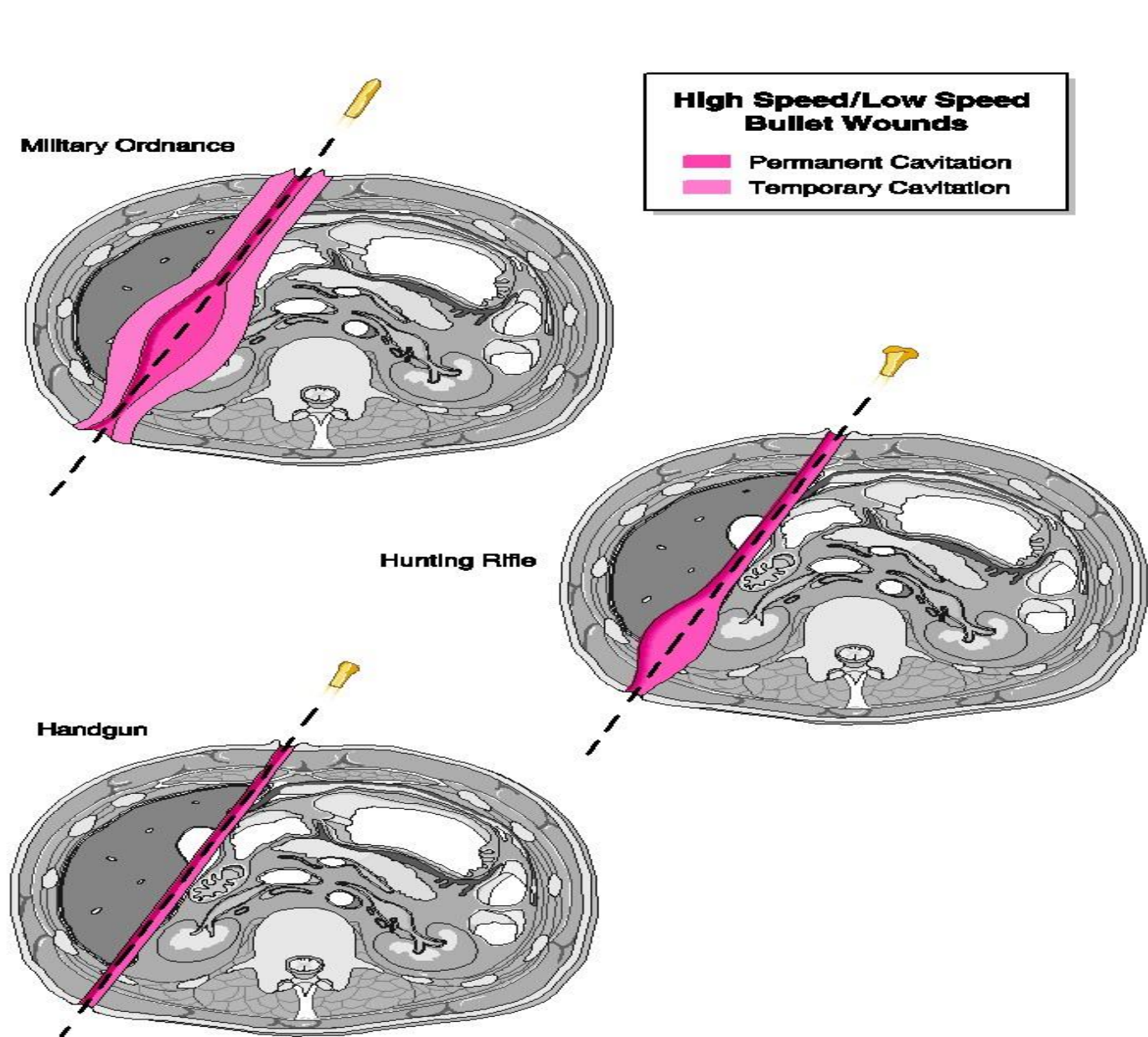



DISTANCE DETERMINATION

- There are four categories of distance for a forensic pathologist/investigator-- distant, intermediate range, near contact, contact
- Distant shot—no powder burns on the skin, no pieces of un-burnt powder (called stippling), a slight grey smudge around the entrance wound called bullet wipe (lubricant, lead, powder, and other materials)
- Intermediate shot—no powder burns, stippling is present(the larger the surface that has stippling, the further the shot was taken from), bullet wipe present on the wound
- Near Contact shot--powder burns on skin, clothing and hair, stippling is present in a very narrow area, bullet wipe hard to see because of other materials present
- Contact shot—Powder burns present, clothing and skin may be torn from the introduction of gases, stippling inside the wound

**= Pathway of the powder
(creating powder burns)**

= Pathway of the bullet

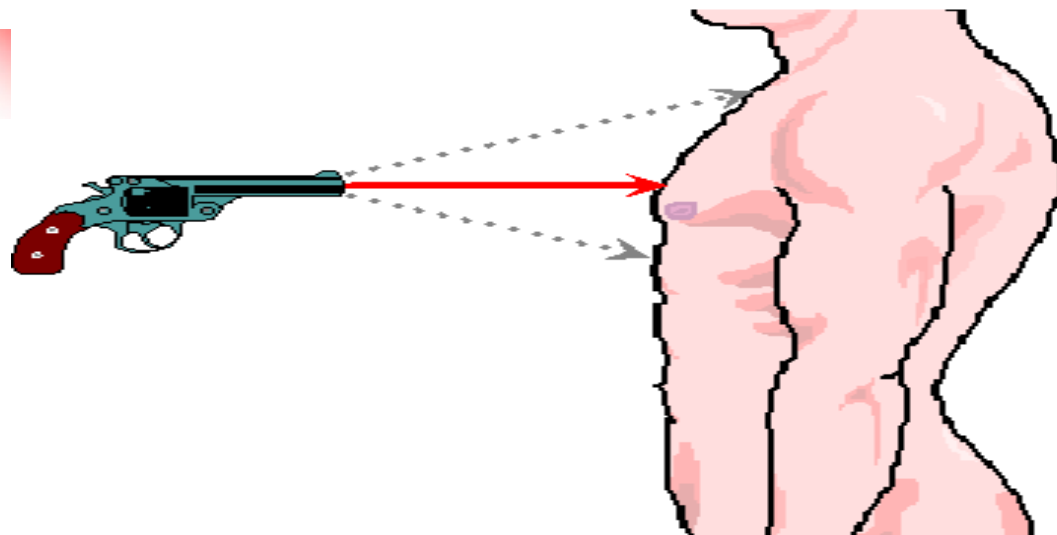

NOTE:

- 1. The greater the distance, the larger the dispersal of the powder burns.**
- 2. The larger the dispersal, the less densely packed the powder burns**

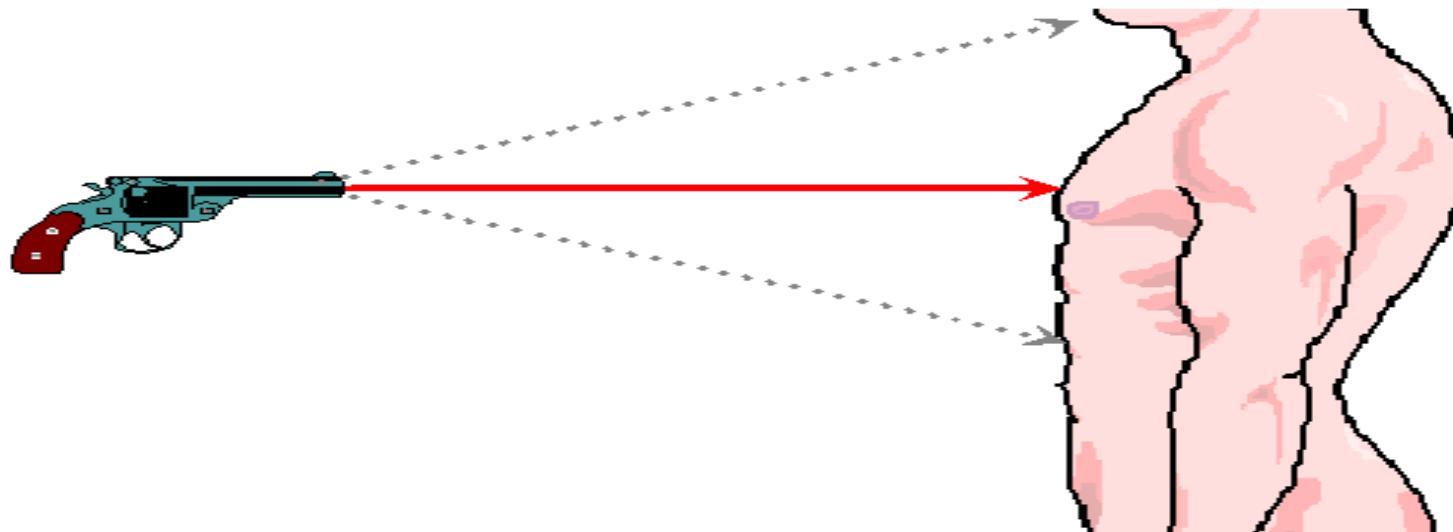

RANGE OF FIRE

- One of the commonest determinations of The forensic pathologist is the range of fire. Gunshot wounds are typically classified as:
- Contact-characteristically have soot on the outside of the skin, and muzzle imprint, or laceration of the skin from effects of gases.
- Close range or Intermediate range- Intermediate or close-range, wounds may show a wide zone of powder stippling, but lack a muzzle imprint and laceration.
- Distant range- are lacking powder stippling and usually exhibit a hole roughly the caliber of the projectile fired.

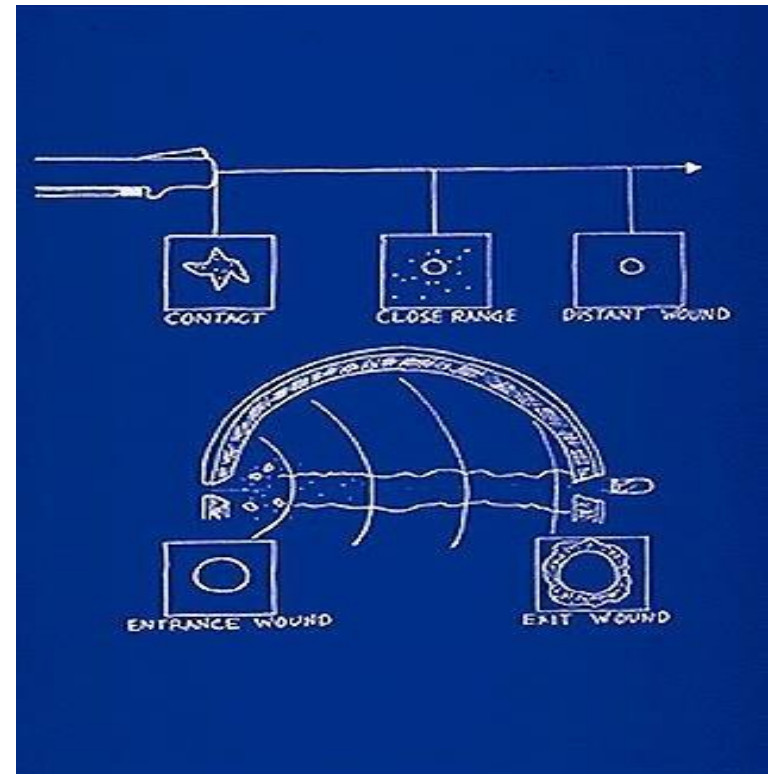

CONTACT WOUNDS



In a hard-contact wound, the muzzle is held tightly against the skin. The cherry- red color of the blood is probably due to carbon Monoxide from the incomplete combustion of gunpowder.



Note barrel-shaped bruise and soot around Bullet wound.



The contact wound may exhibit triangular shaped tears of the skin. These tears are the result of injection of hot gases beneath the skin. These gases will cause the skin to rip and tear in this characteristic fashion.

STIPLINGOR TATTOOING



Stippling or powder tattooing is the term used to describe the circular pattern of dots created around a Gunshot wound when a fire arm is discharged in very close proximity to the Skin.

RADIOGRAPHS OF BULLET DAMAGE



Gunshot injury in a young man who presented to the emergency department with a single bullet hole in the thorax. Arrow and arrow heads show at least three separate clumps of lead which could not possibly have come from a single bullet. An old radiograph from the files shows that two of the clumps of lead pre dated the current injury.



Fractures involving the femur with multiple bone fragments and gun pellets.

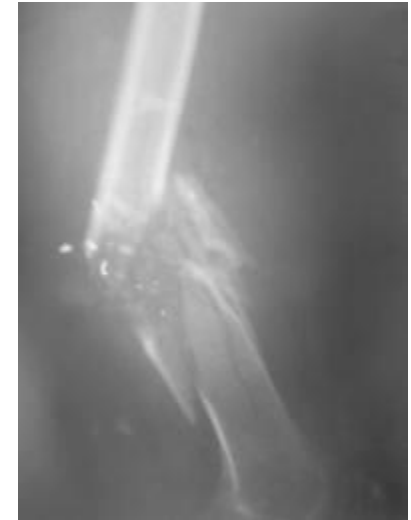

RADIOGRAPHS OF BULLETS



Bullet lodged in
Foot of soldier

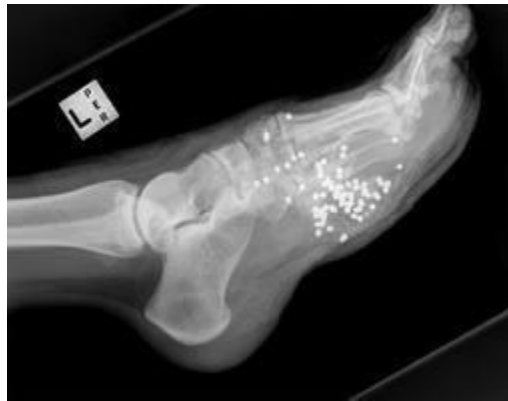

Multiple gunshot pellets in
left foot



.22caliber bullet
Lodged in the skull



Tissue

- **The more dense the tissue the greater the damage (will create permanent cavity)**
ex. Muscle is more dense than lung tissue
- **The more elastic the tissue the less damage because will NOT create a permanent cavity**
ex. Muscle tissue is more elastic than organ tissue

WHAT IS GUNSHOT RESIDUE (GSR)?

Gunshot residue is composed of 2 substances

- (a) propellant(Gun Powder)**
- (b) primer**

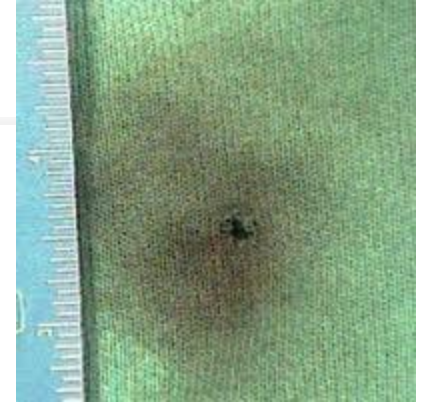

Time-lapse d image showing a bullet exiting from the barrel Streaks of burning gunpowder, smoke, and unburned particulate can be seen exiting the barrel as well.

DIFFERENCE BETWEEN A REVOLVER AND A PISTOL



Colt M1917 Cal. .45 Revolver with 5-1/2 inch barrel



PART - B

VEHICULAR ACCIDENT RECONSTRUCTION

INTRODUCTION

The word accident is derived from the Latin verb accidere, signifying occurrence, happening, falls upon, or by chance. A road accident may be defined as an event which happens suddenly without prior knowledge of the person while walking or driving on the road. Vehicles of different descriptions may be involved in road accidents. In India, the problem has taken alarming proportions as the number of mechanized and nonmechanized (Fig-3a&b) vehicles is increasing rapidly, but the development of infrastructure is not enough to cope up with the situation. Accident is quite often used as a specific legal term. It may be used generally in reference to various types of mishaps, but has a particular significance to Insurance agencies, to which it means a sudden, unintended and fortuitous external and visible event.

In India, a road accident used to be a sensational affair two or three decades ago, whereas now- a-days; it has become something that occupies the headlines of our newspapers almost every day.

Though additional traffic regulations, such as speed limits, and other restrictions have been imposed to reduce the number of accidents, yet the number is increasing.

CAUSES OF ROAD ACCIDENTS

Road accident is most unwanted thing to happen to a road user, though they happen quite often. The most unfortunate thing is that we don't learn from our mistakes on road. Most of the road users are quite well aware of the general rules and safety measures while using roads but it is only the laxity on part of road users, which cause accidents and crashes. Main cause of accidents and crashes are due to human errors. We are elaborating some of the common behaviour of humans which results in accident.

- 1.Over Speeding
- 2.Drunken Driving
- 3.Distractions to Driver
- 4.Red Light Jumping
- 5.Avoiding Safety Gears like Seat belts and Helmets

6. Non-adherence to lane driving and overtaking in a wrong manner

Various national and international researches have found these as most common behavior of Road drivers, which leads to accidents.

Over Speeding:

Most of the fatal accidents occur due to over speeding. It is a natural psyche of humans to excel. If given a chance man is sure to achieve infinity in speed. But when we are sharing the road with other users we will always remain behind some or other vehicle. Increase in speed multiplies the risk of accident and severity of injury during accident. Faster vehicles are more prone to accident than the slower one and the severity of accident will also be more in case of faster the severity of accident will also be more in case of faster vehicles. Higher the speed, greater the risk. At high speed the vehicle needs greater distance to stop i.e. braking distance. A slower vehicle comes to halt immediately while faster one takes long way to stop and also skids a long distance due to law of motion. A vehicle moving on high speed will have greater impact during the crash and hence will cause more injuries. The ability to judge the forthcoming events also gets reduced while driving at faster speed which causes error in judgment and finally a crash.

Drunken Driving:

Consumption of alcohol to celebrate any occasion is common. But when mixed with driving it turns celebration into a misfortune. Alcohol reduces concentration. It decreases reaction time of a human body. Limbs take more to react to the instructions of brain. It hampers vision due to dizziness. Alcohol dampens fear and incite humans to take risks. All these factors while driving cause accidents and many a times it proves fatal. For every increase of 0.05 blood alcohol concentration, the risk of accident doubles. Apart from alcohol many drugs, medicines also affect the skills and concentration necessary for driving. First of all, we recommend not to consume alcohol. But if you feel your merrymaking is not complete without booze, do not drive under the influence of alcohol. Ask a teetotaler friend to drop you home.

Distraction to Driver:

Though distraction while driving could be minor but it can cause major accidents.

Distractions could be outside or inside the vehicle. The major distraction now a days is talking on mobile phone while driving. Act of talking on phone occupies major portion of brain and the smaller part handles the driving skills. This division of brain hampers reaction time and ability of judgement. This becomes one of the reasons of crashes. One should not attend to telephone calls while driving.

If the call is urgent one should pull out beside the road and attend the call. Some of the distractions on road are:

- 1.Adjusting mirrors while driving
- 2.Stereo/Radio in vehicle
- 3.Animals on the road
- 4.Banners and billboards.

The driver should not be distracted due to these things and reduce speed to remain safe during diversions and other kind of outside distractions.

Red Light jumping:

It is a common sight at road intersections that vehicles cross without caring for the light. The main motive behind Red light jumping is saving time. The common conception is that stopping at red signal is wastage of time and fuel. Studies have shown that traffic signals followed properly by all drivers saves time and commuters reach destination safely and timely. A red light jumper not only

jeopardizes his life but also the safety of other road users. This act by one driver incites other driver to attempt it and finally causes chaos at crossing. This chaos at intersection is the main cause of traffic jams. Eventually everybody gets late to their destinations. It has also been seen that the red light jumper crosses the intersection with greater speed to avoid crash and challan but it hampers his ability to judge the ongoing traffic and quite often crashes.

Avoiding Safety Gears like seat belts and helmets:

Use of seat belt in four-wheeler is now mandatory and not wearing seat belt invites penalty, same in the case of helmets for two wheeler drivers. Wearing seat belts and helmet has been brought under law after proven studies that these two things reduce the severity of injury during accidents. Wearing seat belts and helmets doubles the chances of survival in a serious accident. Safety Gears keep you intact and safe in case of accidents. Two wheeler deaths have been drastically reduced after use of helmet has been made mandatory. One should use safety gears of prescribed standard and tie them properly for optimum safety.

Detrimental effects of traffic on environment

1. Safety 2. Noise 3. Land Consumption 4. Air Pollution 5. Degrading the Aesthetics

How different factors of Roads contribute in Accidents:

Drivers: Over-speeding, rash driving, violation of rules, failure to understand signs, fatigue, alcohol.

Pedestrian: Carelessness, illiteracy, crossing at wrong places moving on carriageway, Jaywalkers.

Passengers: Projecting their body outside vehicle, by talking to drivers, alighting and boarding vehicle from wrong side travelling on footboards, catching a running bus etc.

Vehicles: Failure of brakes or steering, tyre burst, insufficient headlights, overloading, projecting loads.

Road Conditions: Potholes, damaged road, eroded road merging of rural roads with highways, diversions, illegal speed breakers.

Weather conditions: Fog, snow, heavy rainfall, wind storms, hail storms.

Preventive measures for accidents:

1. Education and awareness about road safety
2. Strict Enforcement of Law

3. Engineering:

- (a) Vehicle design (b) Road infrastructure

The Three Basic Steps of an Accident Reconstruction

Performing a thorough and accurate accident reconstruction generally involves a systematic and consistent approach. The three basic steps consist of:

1. Data collection and evidence preservation
2. Analysis
3. Communication of findings

➤ ***Data Collection and Evidence Preservation***

Whether the accident happened within the past few hours or is years old, a thorough reconstruction will typically involve some collection of data from the field or other sources. In some

instances, a detailed inspection of the site of the accident may be necessary. Additionally, inspections can be performed on other elements involved in an accident, such as vehicles, broken objects, or clothing, to name just a few.

Beyond this, inspections of **exemplar** items may also prove valuable. An **exemplar** is an undamaged vehicle/vessel/component that is identical to the make, model, and equipment associated with the accident-involved vehicle/vessel/component. Reconstructionists use state-of-the art technology to fully capture any relevant data and evidence from the exemplar, scene, or other elements of the accident. For example, the following tools frequently prove helpful in performing a thorough reconstruction:

1. Digital video and photography
2. Unmanned aerial imagery, i.e., drones
3. 3D Laser Scanning
4. Low light photography
5. Light metering

6. Headlight mapping
7. Sound pressure level measurements
8. Binaural or ambisonic audio capturing

In cases involving automobile collisions, whether passenger or commercial vehicles, a variety of tools can be used to extract information from accident-involved vehicles. Information can be collected from Event Data Recorders (EDRs or “black boxes”), security cameras, Lytx Drivecams, Heavy Truck ECMs, and several other sources. More recently, the prevalence of GPS tracking and infotainment systems may provide key information on vehicles, trucks and even recreational boats. In addition to information that can be obtained from physical inspections, reconstructionists have a variety of databases and other resources at their disposal containing relevant information relating to vehicles in a collision.

Understanding the sources of available data and evidence is an important element in the reconstruction of any event. Finding and consulting a qualified and experienced expert in reconstruction can prove very beneficial when determining and accessing all sources of useful data and evidence.

➤ *Analysis*

Having access to all of the available data and evidence is critical, but knowing what to do with it once it is collected is equally important. The available data and evidence must be considered together to determine what analysis tools are appropriate. Reconstructionists will utilize a variety of tools when performing an analysis of a specific event. These tools include hand calculations, spreadsheets, CAD drawings and layouts, and advanced 3D physics-based simulation tools.

When necessary, a 3D digital twin of the environment is created utilizing the information obtained during a site inspection. A **digital twin** of the environment, combined with collected data, calculations, and simulations, can be used to determine the time-distance relationship of various objects and vehicles/vessels associated with an accident, in addition to assessing issues of visibility. Ultimately, this data is synthesized to determine a full 3D dynamic understanding of what happened during an accident.

➤ *Communication*

Performing an accurate and thorough reconstruction of an event is all but worthless if the findings are unable to be simply and concisely communicated. Often, the most effective means to

communicate the findings of an accident reconstruction is to show it. Fortunately, most of the techniques and tools used to perform the aforementioned data and evidence collection and analysis can be used and combined to create a full, physics-based representation of what happened in an accident. Rather than generating an artistic rendering of an accident, these representations capture the science of a reconstruction and present it with incredible accuracy and clarity.